



Aeration products

FOR ENERGY-EFFICIENT BIOLOGICAL TREATMENT



Greater energy savings are in the air

Stricter environmental regulations and rising energy costs are forcing wastewater treatment plants to ensure wastewater discharge compliance and at the same time make operations more energy efficient. One of the main areas for environmental and cost savings lies just below the surface of your biological tanks.

Uncover submerged energy savings

Aeration systems today represent an estimated 30 to 70 percent of the total energy costs at a typical wastewater treatment plant. By making your plant's biological treatment processes more efficient, you can realize big energy savings and lower your operating costs.

Reliable cost-effective aeration solutions

Proven reliable for more than 40 years, comprehensive aeration solutions from Sanitaire and Flygt meet virtually every need and operating condition. From fine-bubble diffusers complete with framework, piping, supports and energy-saving blowers to coarse-bubble diffusers and stand-alone mechanical aerators, our aeration systems reduce both your capital expenditures and operating and maintenance costs. Plus they are backed by precise monitoring and control systems.

Optimizing your aeration processes

Although we offer the best aeration equipment, equipment isn't everything. Competence is. Our

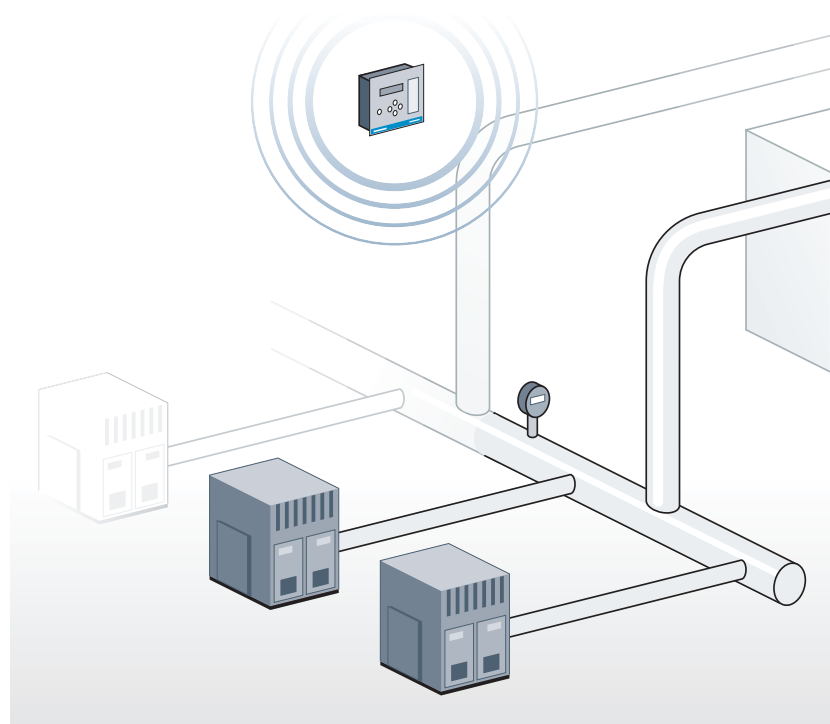

engineers put more than four decades of expertise and a true passion for high oxygen transfer to work to ensure environmentally sound operations at your plant. So everything you need to know about improving your aeration processes is available through a single and reliable partner.

We understand how different operating strategies

Contents

	Page
Diffused aeration	4-11
· Sanitaire Gold Series diffusers	5
· Sanitaire Silver Series II diffusers	6
· Sanitaire ceramic diffusers	7
· Sanitaire diffuser holders	8
· Sanitaire grid components	9
· Sanitaire coarse bubble wide-band diffusers	10
· Blowers	11
Mechanical aeration	12-13
· Flygt jet aerators	12
Monitoring and control	14
Support and service	15

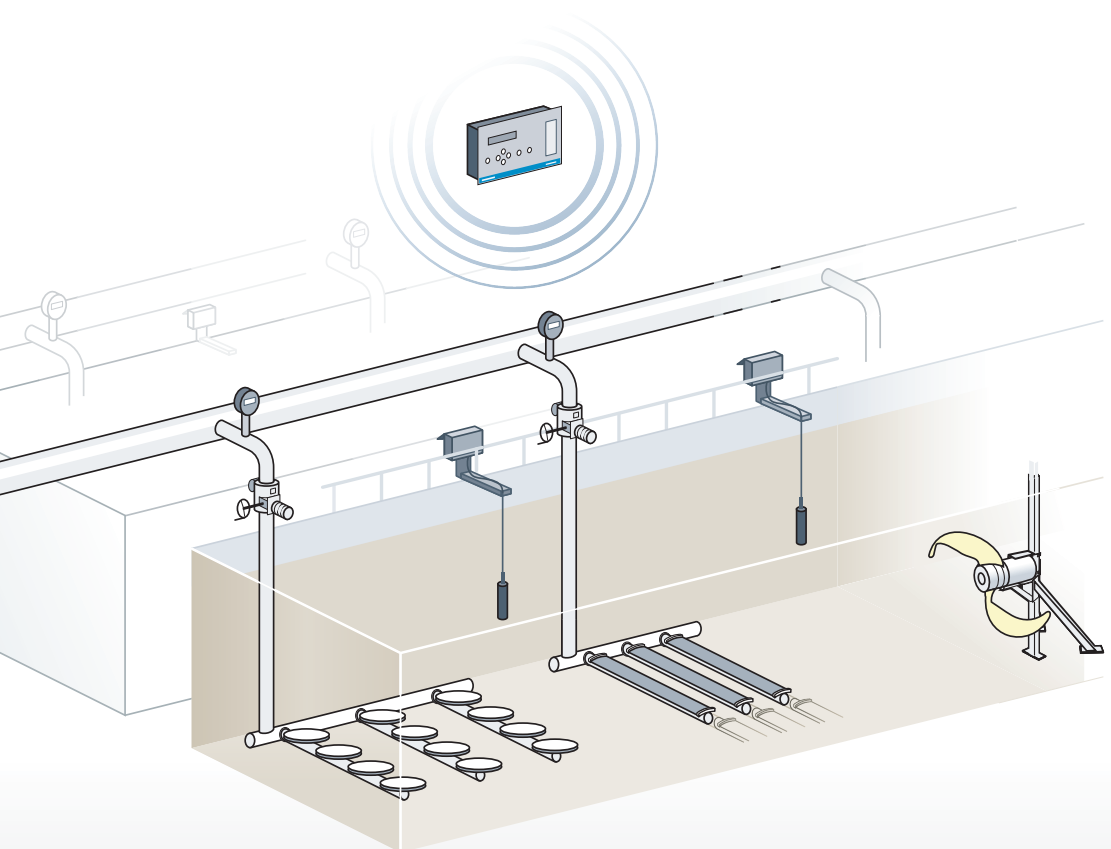

To optimize your process, we design, deliver, commission and, through control systems, support the operation and maintenance of your aeration system - from blowers to diffusers.

More oxygen delivered per kilowatt hour

Factors to consider when designing your aeration system:

Standard oxygen transfer efficiency (SOTE)

Used to compare oxygen transfer efficiency, SOTE is the ratio between the amount of oxygen transferred and the amount actually delivered. Performance can reach up to 60% depending on the water depth and airflow rate.

Standard aeration efficiency (SAE)

SAE is the ratio between the amount of oxygen transferred to the water and the amount of energy used. Typical values are 1-2 kg O₂/kWh for mechanical aeration systems and 2-8 kg O₂/kWh for diffused aeration systems.

SAE reflects both SOTE as well as blower efficiency and the system pressure loss.

and equipment selection affect energy consumption and costs. So we can determine where additional operational efficiencies can be realized. Introducing an automated monitoring and control system or combining diffusers with mixers, for instance,

can drastically boost efficiency and energy savings.

Whatever the challenge, be sure to take advantage of our vast aeration engineering expertise. This not only will improve aeration efficiency at your plant, but enable you to focus on increasing the profitability of your core business.

Which aerator is right for you?

Treatment stages	Applications	Diffused aeration	Mechanical aeration
Preliminary and primary	Grit chamber	Coarse bubble	
	Retention basin	Coarse bubble/Fine bubble	Jet aerator
Secondary	Biological aeration	Fine bubble	Jet aerator
Tertiary	Aeration before discharge	Fine bubble	
Sludge	Aerobic digestion		Jet aerator
	Sludge holding	Coarse bubble/Fine bubble	Jet aerator
	Odor control	Fine bubble	Jet aerator

Dissolving into thin air



Grid components

To support Sanitaire fine bubble diffused aeration systems, we offer standardized grid components.

See page 9.

For reliable oxygen transfer in all types of wastewater aeration applications, choose Sanitaire® diffused aeration systems. No matter the tank geometry or process application, Sanitaire systems have proven effective in thousands of communities and industries worldwide.

Customize your system

Select the right components from the Sanitaire range and combine them with an air piping system, required support and an energy-efficient blower.

Fine-bubble diffusers

Sanitaire fine-bubble diffusers are generally employed for biological aeration, pre-discharge aeration and sludge holding odor control. Choose

between Sanitaire Gold Series for high efficiency, Sanitaire Silver Series II membrane diffusers for standard and low-pressure aeration applications and the durable Sanitaire ceramic diffusers for applications that require corrosion resistance.

Coarse-bubble diffusers

For tougher applications such as sludge or industrial wastewater, Sanitaire coarse-bubble diffusers are the preferred technology. Typically used in grit chambers, retention tanks and sludge holding tanks, the Sanitaire wide-band diffuser doesn't disappoint.



Air supply

No aeration system would be complete without an air supply and distribution system. Using in-house tools, we optimize designs for temperature and pressure considerations. We also complement Sanitaire aeration system with dependable blowers.

See page 11.

Sanitaire Gold Series diffusers

Sanitaire Gold Series membrane diffusers are the latest innovation in fine-bubble aeration technology. Wherever high-density coverage and low flux rates are required, these can be tightly packed across any given basin floor area to provide unsurpassed aeration efficiency.

Energy efficiency

The unique diffuser geometry, and advanced micro-punched membrane enable high-density basin floor coverage and low air flux, which together provide high oxygen transfer using the lowest possible amount of energy. The membrane is engineered for low head loss thereby reducing energy consumption further.

High reliability

Thick, highly pliable polyurethane membranes outlast others in accelerated aging tests. Dependability is further enhanced by the watertight construction of the end fittings and sealing system, which withstand the stress of daily operation. It has even proven to be adapted to air-on/air-off applications.



Ease of installation

Compactness makes these complete, pre-assembled diffusers easy to install. This translates into faster commissioning, smarter use of resources and, ultimately, higher productivity.

Modularity

Modular design facilitates installation as well as low-cost, no-hassle retrofits because all Sanitaire components are interchangeable to enable optimization of aeration system performance.

Performance curves
Gold Series

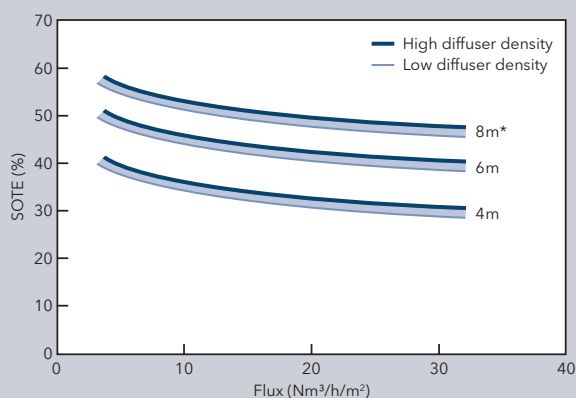

*Submergence

Technical data

Membrane material	Polyurethane
Lengths	2,286 mm (90 in) 1,500 mm (59 in) 700 mm (28 in)
Airflux range	3.7-37 Nm³/h /m² 0.2-2 scfm /ft²
Standard oxygen transfer efficiency (SOTE)	7-10% per m submergence 2.2-3% per ft
Standard aeration efficiency (SAE)	3-8 kg O₂ /kWh 8-15 lbs O₂ /hph

Sanitaire Silver Series II diffusers

For a combination of high aeration efficiency and low operating costs, there's the Sanitaire Silver Series II membrane diffuser - the most widely used fine bubble diffused aeration system available today.

High oxygen transfer efficiency

The Sanitaire Silver Series II membrane features a unique slit pattern and slit shapes, which disperse air bubbles in an extremely fine, uniform pattern for optimal oxygen transfer.

Long service life, low maintenance

The high elasticity and degradation-resistance of specially blended high-grade EPDM elastomer compounds contribute to a service life of 10 or more years.

Operating efficiency

The unique membrane shape, integrated O-ring and top-sealing threaded retainer ring eliminates leakage. This reduces energy consumption and raises operating efficiencies.

Great application flexibility

A highly effective, integrated check valve enables the aeration zones to easily be shut down for air-on/air-off applications.



Sanitaire Silver Series II LP

This 9" low-pressure version of the Sanitaire Silver Series II membrane features a modified slit pattern to handle airflow up to 17Nm³/h (11 scfm) with minimal pressure loss. It is an excellent choice for sludge and other heavy-duty applications.

Performance curves
Silver Series II

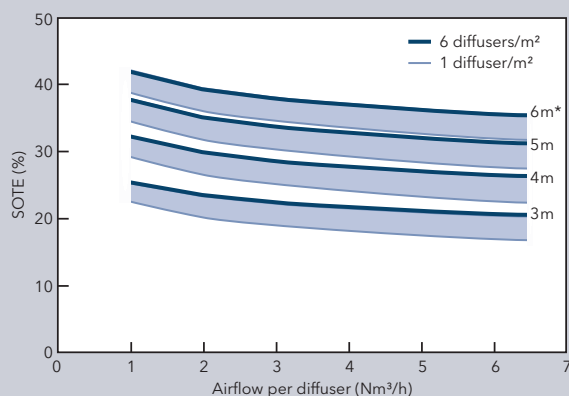

Technical data

Disc material	Specially blended high-grade EPDM
Diameter	178 or 229 mm (7 or 9 in)
Airflow range per disc	0.8-7 Nm ³ /h (0.5-4.5 scfm)
Standard oxygen transfer efficiency (SOTE)	Approx. 6.5% per m submergence (2% per ft)
Standard aeration efficiency (SAE)	2.5-6 kg O ₂ /kWh (4-10 lb O ₂ /hph)

Sanitaire ceramic diffusers

Sanitaire ceramic diffusers handle aeration of aggressive, highly corrosive wastewater, delivering high oxygen transfer both efficiently and cost effectively.

Low total cost of ownership

Sanitaire ceramic discs are specially compression-molded to achieve optimal contours for high oxygen transfer efficiency at low operating pressures. Variable areas of density across the disc surface promote uniform airflow distribution. This contributes to low system head loss, low energy consumption, low operating costs and, thereby, a low total cost of ownership.

Energy efficiency

Sanitaire ceramic discs feature a top-sealing threaded retainer ring, which ensures an airtight seal. As air pressure increases, the sealing force on the O-ring increases thus creating an airtight seal. Because there are no air leaks, no energy is wasted.

20-year-long life expectancy

Durable, reliable and clog-resistant, Sanitaire ceramic discs are low-maintenance diffuser elements that typically last 20 or more years. To prolong service life further, an optional in-place gas cleaning system enhances continuous performance.



Performance curves

9" ceramic

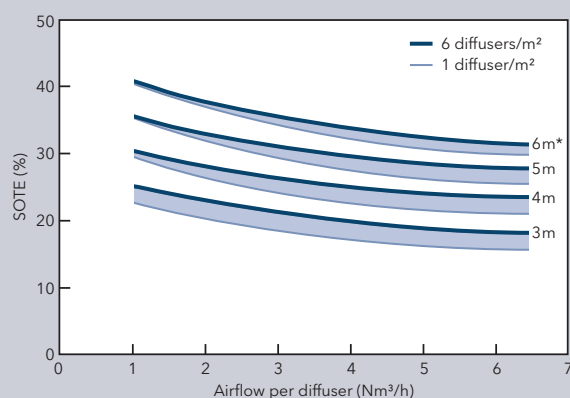

*Submergence

Technical data

Disc material	Special compression-molded ceramic
Diameter	178 or 229 mm (7 or 9 in)
Airflow range per disc	0.5-4.7 Nm ³ /h (0.3-3 scfm)
Standard oxygen transfer efficiency (SOTE)	Approx. 6.5% per m submergence (2% per ft)
Standard aeration efficiency (SAE)	2.5-6 kg O ₂ /kWh (4-10 lb O ₂ /hph)

Sanitaire diffuser holders

These easy-to-install Sanitaire diffuser holders provide superior mechanical strength to support Sanitaire Gold Series and Silver Series II membranes and Sanitaire ceramic discs.

Sanitaire 2300 holder

Designed for use with Sanitaire Silver Series II membranes, Sanitaire Silver Series II LP membranes and Sanitaire ceramic discs.

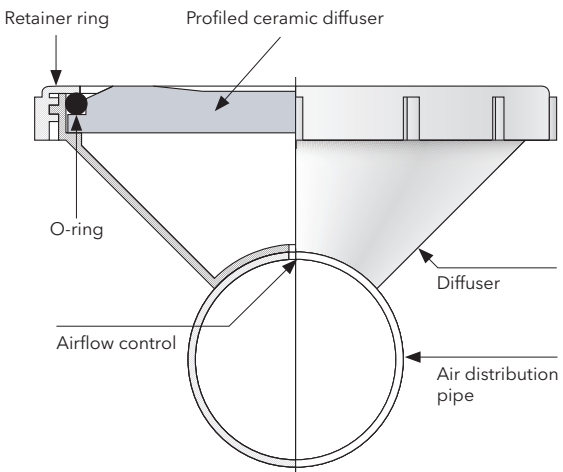
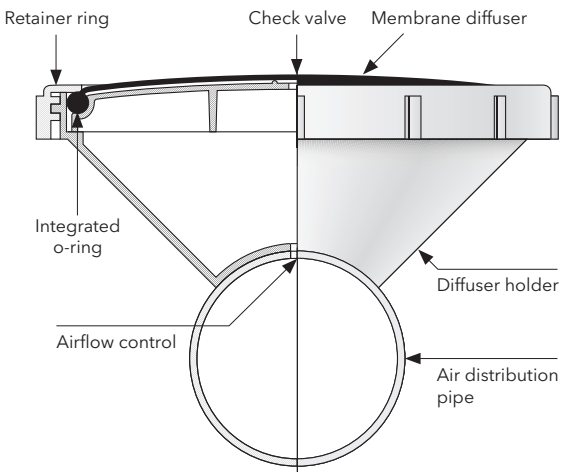

Sanitaire 2802 holder

A cost-effective alternative, the Sanitaire 2802 is designed for use with the Sanitaire Silver Series II and Silver Series II LP membranes.

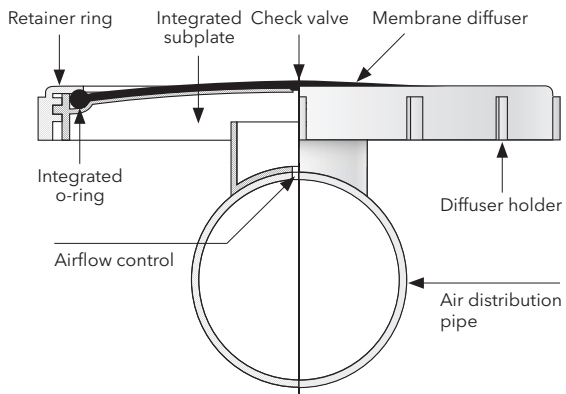

Sanitaire Gold Series holder

Designed for use with Sanitaire polyurethane membranes and based on the highly efficient cross-section of the 7" holder.

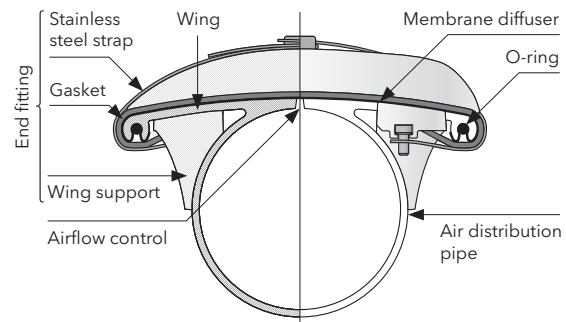

Sanitaire grid components

Beneath every Sanitaire diffused aeration system is a solid foundation. These components are integral to the Sanitaire fine bubble range and hold important supporting roles.

Solid framework

Patented Sanitaire spline joints ensure firm connection of air supply pipes from the dropleg to the diffusers. Engineered to withstand thermal expansion and contraction, water hammer and other dynamic stress, these spline joints securely fasten the pipes, thereby preventing air leakage, pipe blowpart and pipe rollover.

Upstanding system support

Made of durable corrosion-resistant stainless steel, Sanitaire guide supports securely anchor Sanitaire diffused aeration systems. These robust threaded supports feature an infinite height adjustment mechanism to ensure accurate grid leveling. The pipe bracing assembly accommodates pipe expansion while providing a stable foundation. Specially reinforced Sanitaire guide supports are available for high velocity and mixer zones.

Easy to adapt

Sanitaire air distribution pipes are delivered with factory-welded diffuser holders and Sanitaire Gold Series are delivered as pre-assembled units, to facilitate installation. Moreover, Sanitaire grid components are fully interchangeable with your existing system. To meet more stringent emissions

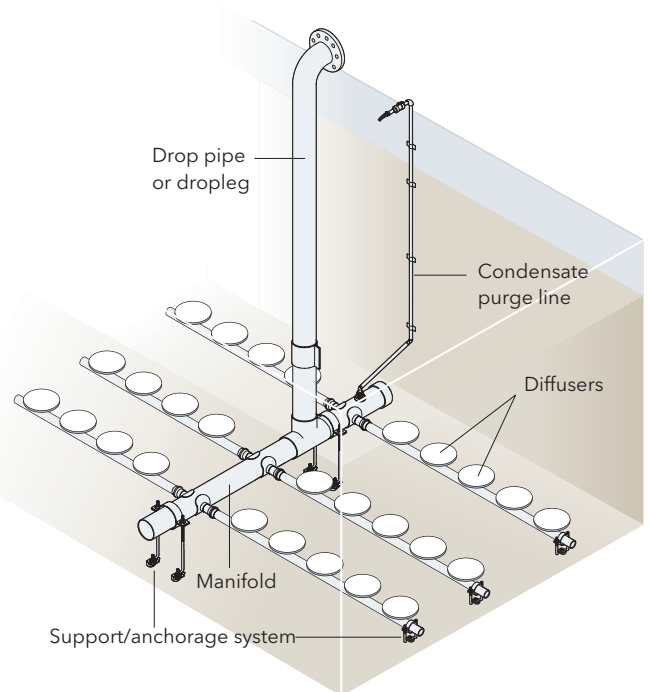

requirements, for example, it's easy to replace Sanitaire ceramic discs with Sanitaire Gold Series or Silver Series II membranes.

Aeration purging

After condensation, water levels in the manifold can rise and extend to the headers. To deal with water buildup, we offer a separate purge system that removes condensate from the lowest point in the system.



Spline joints



Adjustable grid support

Technical data

Dropleg	Stainless steel AISI 304 or 316
Manifolds	Stainless steel, specially formulated polyvinyl chloride (PVC) to prevent UV degradation.
Distribution headers	PVC or CPVC for higher temperatures
Supports and anchor bolts	Stainless steel AISI 304 or 316
Gaskets	EPDM

Sanitaire coarse bubble wide-band diffuser

The Sanitaire stainless steel wide-band diffuser is an excellent choice and a smart alternative to mechanical aeration. It is especially suited to tough sludge-related applications such as aerobic sludge digestion, grit chambers, flow equalization and channel aeration.

Clog-resistant, maintenance-free design

The Sanitaire wide-band diffuser features an innovative inverted air reservoir. This stores a sufficient air volume at the centre of the diffuser for use to ensure continuous and uniform airflow. This prevents clogging. Another smart feature is a bottom deflector, which prevents the entry of debris into the diffuser and reduces the need for maintenance.

Erosion/corrosion resistance

Thanks to immersion passivation after fabrication, the Sanitaire wide-band diffuser is erosion/corrosion-resistant and maintains full structural integrity even in welded heat-affected zones. This prolongs service life.

Solid oxygen transfer efficiency

Dual horizontal levels of diffusion ports on the diffuser side ensure uniform air distribution and aeration efficiency.

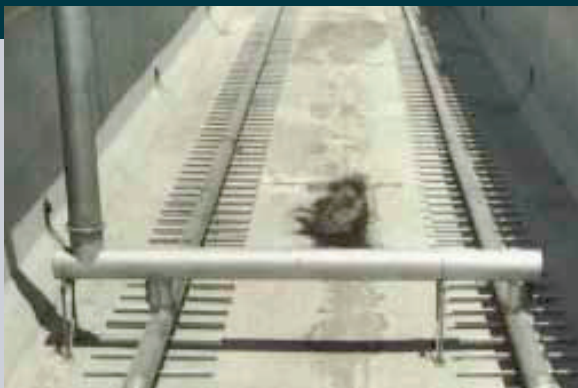

Technical data

Material	Stainless steel AISI 304 or 316
Length	305 or 610 mm (12 or 24 in)
Airflow range per band	15-63 Nm ³ /h (10-40 scfm)
Standard oxygen transfer efficiency (SOTE)	1.6-2.5% per m submergence (0.5-0.8% per ft)
Standard aeration efficiency (SAE)	0.7-2 kg O ₂ /kWh (1.1-3.5 lbs O ₂ /hph)

Blowers

Optimizing your aeration systems is of paramount importance. Which is why we can complement every Sanitaire diffused aeration system with a fully packaged blower system that is reliable, energy-efficient and easy to maintain.

It takes experience and expertise to select the right blower for your aeration system. We have both. We understand the parameters that influence blower selection - from energy efficiency and reliability to life cycle cost, operational flexibility and installation footprint through to noise levels and maintenance requirements.

Whatever your aeration needs, we help you select the right blower from among these technologies, which are typically found in a wastewater treatment plant.

Rotary lobe blowers

A pair of spinning rotors delivers a fixed volume of air for each rotation. Rotary lobe blowers rely upon external compression whereby the air is compressed by the system backpressure. While these offer the advantage of low capital investment costs upfront, they also provide low efficiency.

Screw rotor blowers

A pair of intermeshing screws progressively reduces the volume of air as it moves along the length of the screw element. These provide higher efficiency than other positive displacement blowers due to the use of internal compression.

Multi-stage centrifugal blowers

Multiple impellers are mounted on a single low-speed shaft normally operating at a fixed speed. These are employed for larger flows and require less capital investment than other types of



centrifugal blowers, however are also generally less efficient.

Single-stage, integrally geared centrifugal blowers

A single impeller achieves higher rotational speed via a step-up gear. These can be equipped with variable inlet guide vanes and diffuser vanes to achieve high efficiency over a range of operating flows. Single-stage, integrally geared blowers are more efficient than positive displacement and multi-stage centrifugal blowers.

Variable-speed, single-stage direct-drive centrifugal blowers

A single or dual impeller is mounted directly on to the shaft of a high-speed motor with low-friction magnetic or air foil bearings. These have integrated VFD (variable frequency drive) to match pressure and flow rate demands. While more expensive than positive displacement and multistage centrifugal blowers, these are more efficient, with magnetic bearing blowers often being more efficient than those with air foil bearings.

Flygt jet aerators



Proven N-technology

Flygt jet aerators feature Flygt N-pumps with N-technology, renowned for its non-clogging design and high efficiency.



Ejector assembly

The robust, non-clogging ejector assembly creates high turbulence where wastewater combines with air to form a liquid jet containing fine air bubbles.



Damper feet

Robust stand with damper feet prevents vibration, which could damage the ejector system.

Mechanical aeration systems from Flygt provide an affordable alternative to our highly efficient diffused aeration systems. Convenient lift-in, lift-out solutions, submersible Flygt jet aerators provide reliable, low-cost oxygen transfer for small to medium-sized sludge tanks, retention tanks and bio-reactors.

Quick, low-cost installation

Convenience doesn't come easier than with Flygt jet aerators. Simply lift and position these stand-alone aeration systems into any small to medium-sized tank without having to empty it, using the Flygt pump lift and chains. Installation is complete. Then plug in Flygt jet aerators and let them work. No blowers, special housing or superstructures are required.

Proven long-term reliability

Flygt jet aerators provide maximum uptime and minimal maintenance. Proven N-technology, a specially engineered Flygt ejector assembly and air suction pipe bend combine to provide high operational reliability.

Better working environment

Because the submersible Flygt jet aerator rests on the tank bottom, there's significantly less spray and lower noise levels and vibrations. This greatly improves the working environment.

Operational flexibility

Compact Flygt jet aerators fit into any tank regardless of size or shape. Choose the Flygt pump capacity, number of mechanical ejectors and materials that match your requirements. Pumps can serve between one and three ejectors.

Erosion/corrosion-resistant operation

Greater durability can be achieved by choosing the stainless steel ejector assembly and Hard-Iron™ N-impeller over the standard galvanized steel ejector assembly and cast iron N-impeller.



The Flygt jet aerator consists of air suction pipes, an N-pump, ejector housings and ejectors.

Performance curves

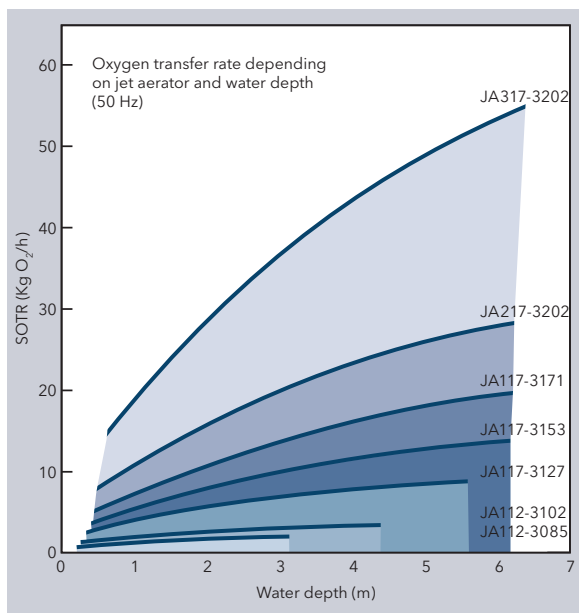

Working principle; The velocity of the water creates air suction which is mixed in the ejector and transferred into the wastewater tank.

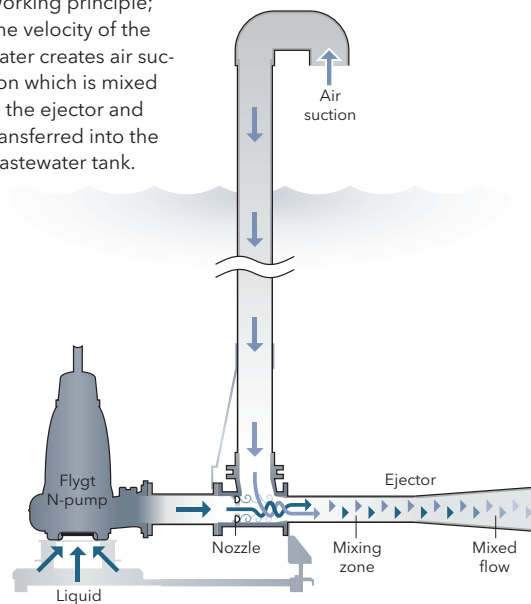

Technical data

Model	JA112	JA112	JA117	JA117	JA117	JA217	JA317
SOTR at 4m (13 ft) depth							
50Hz, kgO ₂ /h	1.5*	3.2	7.5	11	15	22	40
60Hz, kgO ₂ /h (lbsO ₂ /h)	2.2 (4.8)	3.3 (7.3)	7.8 (17)	12 (26)	17 (37)	30 (66)	43 (95)
Ejectors	1	1	1	1	1	2	3
Nozzle outlet diameter (mm)	55	55	95	95	95	95	95
Flygt N-pump	3085 MT	3102 MT	3127 MT	3153 MT	3171 MT	3202 MT	3202 LT
Rated power, kW (hp)							
50 Hz	2	3.1	5.9	9	15	22	37
60 Hz	2.2 (3)	3.7 (5)	7.5 (10)	11.2 (15)	18.6 (25)	34 (45)	45 (60)
Cooling jacket	-	-	-	•	•	•	•
Standard aeration efficiency (SAE)	←----- 0.5-1.2 kgO ₂ /kWh (0.8-2 lbsO ₂ /hph) ----->						

* At 3m (10 ft) depth.

Empowering system performance

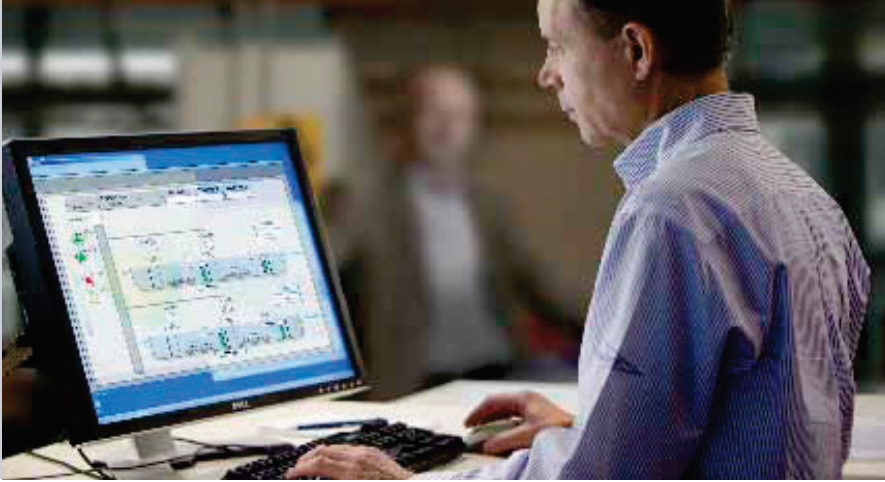

Take command of the performance of your aeration systems with our monitoring and control systems. To help you meet your responsibilities in a constantly changing environment, you can rely on us to put you in total control of your entire plant or plant subsystem/s.

Saving energy on a daily basis

The Flygt APX process controller automatically adapts the air supply to your oxygen requirements based on daily and seasonal variations. This drastically reduces power consumption and boosts energy savings by up to 40%. The information in our systems flows seamlessly to most existing third-party control system. So after installation, you can immediately begin saving more energy.

Total control, total performance

For full end-to-end control of your entire plant, combine the Flygt APX process controller with the Flygt AquaView SCADA system. Both are based on open standards, no special interfaces are required to communicate with most programmable logic controllers (PLCs) or SCADA systems. This makes continuous real-time

monitoring of individual components possible. It also provides detailed data on events to identify trends and diagnose problems before they even occur. With total control, you can boost energy efficiency every step of the way and raise performance at your plant.

Total peace of mind

We understand that system reliability is of paramount importance. With us as your single reliable partner, you not only can improve control over your operations, but improve productivity and profitability. Managing your plant from any remote location is easy, thanks to web-based tools and online support. What's more, our control systems are flexible, scalable and future-proof and can accommodate additional equipment in virtually any treatment plant configuration.



Flygt AquaView SCADA system

- Provides a complete plant overview
- Collects and stores data to identify trends and diagnose problems before they occur
- Provides extensive alarm handling



Flygt APX 700 process controller

- Distributes the required oxygen to tanks and grids
- Operates blowers at optimal efficiency
- Provides extensive alarm handling

Aeration expertise runs deep



Combining aeration & mixing technologies

To deliver high oxygen transfer and mixing efficiencies with minimal energy consumption, you can rely on our engineers to share their knowledge about system design.



Comprehensive system design services

- System simulation utilizing CFD
- Engineering software development
- Advisory services
- System design assistance
- System specification assistance
- Oxygen transfer testing
- Model testing

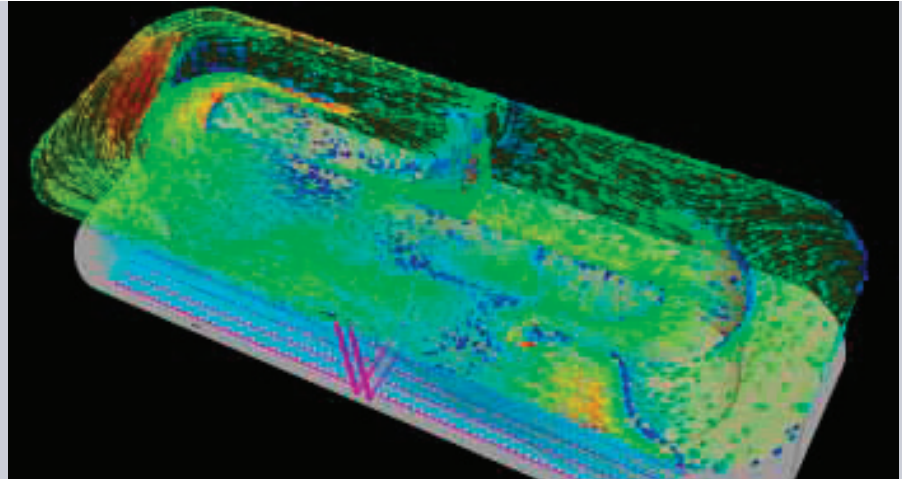

We are passionate about the design and execution of comprehensive aeration treatment solutions. We have knowledge and understanding of the aeration process to safeguard the wellbeing of your business and the environment.

Extensive systems engineering

Our competence in systems engineering runs deep. We can assist you every step of the way - from developing mixing and aeration specifications to shop testing. Through thorough aeration design analysis, we are able to achieve the highest possible oxygen transfer while using the least possible amount of energy.

Smart tools to analyze aeration design

Our engineers combine their experience and expertise with specially developed software programs and tools so that we can design new and existing aeration installations tailored to your requirements.

Computational fluid dynamics (CFD) programs enable our engineers to simulate your aeration operating conditions, determine how best to optimize flow turbulence in your tanks and minimize energy consumption.

We use system temperature and pressure calculations to determine the optimal conditional for every single component in your entire aeration system - from blower to grid.

Grid configuration is another area where we excel. We tailor your grid to meet your requirements for oxygen transfer.

Support all along the way

Customers worldwide have come to rely on us for comprehensive range of aeration system components and accessories, spare parts and support. Whatever your requirements, we support you all the way - from designing and commissioning to optimizing and maintaining your aeration systems.

Xylem ['zīləm]

- 1) The tissue in plants that brings water upward from the roots
- 2) A leading global water technology company

We're 12,000 people unified in a common purpose: creating innovative solutions to meet our world's water needs. Developing new technologies that will improve the way water is used, conserved, and re-used in the future is central to our work. We move, treat, analyze, and return water to the environment, and we help people use water efficiently, in their homes, buildings, factories and farms. In more than 150 countries, we have strong, long-standing relationships with customers who know us for our powerful combination of leading product brands and applications expertise, backed by a legacy of innovation.

For more information on how Xylem can help you, go to xylem.com.



BAO BINH TECHNOLOGY CO., LTD

Address: 816/20 Truong Sa, Ward 14, District 3, HCMC, Vietnam.

Tel. +84 28 38420440 Fax. +84 28 38420460

www.bbtec.com.vn



Flygt and Sanitaire are brands of Xylem.

For the latest version of this document and more information about Flygt and Sanitaire products visit

www.flygt.com

www.sanitaire.com