

Solids Handling Pump - Stainless Steel

Capacity up to 260 GPM, Heads up to 90 ft.



Applications:

CS/DS-3060 is ideal for pumping water containing corrosive materials in concentration 3-14 pH.

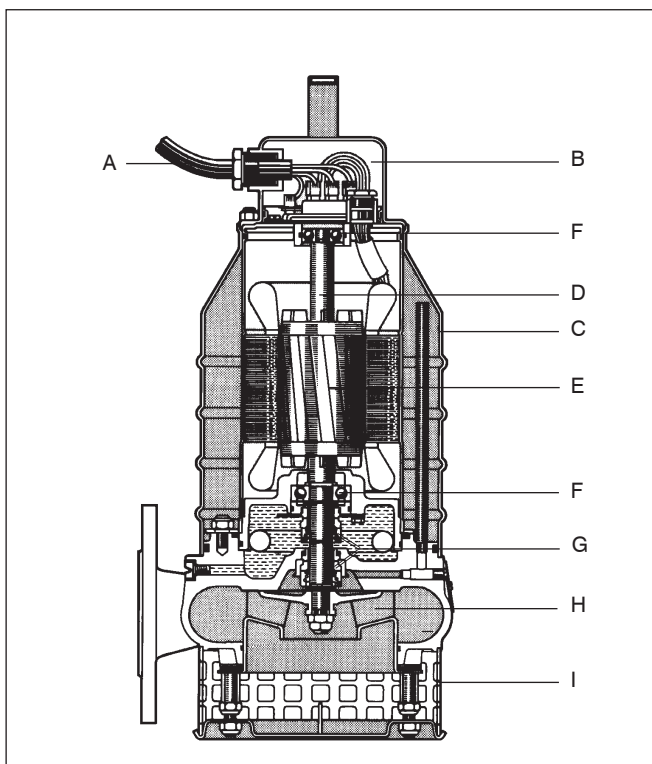

Specifications

- A **Cable.** Standard 50 ft. of AWG 12/7 SubCab cable.
 - B **Junction Chamber.** Cable entry incorporates a strain relief and grommet controlled compression sealing. Between the junction box and stator housing a rubber gland provides additional seal protection of the motor.
 - C **Pump Housing.** Stainless steel AISI 316. Static seals are leakproof Nitrile rubber O-rings in precision machined grooves, with controlled compression.
 - D **Shaft.** Stainless steel AISI 329.
 - E **Motor.** Air filled, NEMA design B with class H (180°C) insulation; 2 pole, 3400 rpm. Shrink-fit to the motor housing. Allows at least 10 starts per hour. Built-in Thermal sensors for additional motor overload protection (optional).
 - F **Bearings.** Upper and lower: single row ball bearing.
 - G **Shaft Seals.** Independent double face seals running in environmentally friendly, FDA approved (Standard #172.878) lubricant. Upper seal: carbon/ ceramic. Lower seal: ceramic/ceramic. Oil specs: .9 pints (0.5 l).
 - H **Impeller.** Multivane, open radial type (CS) or vortex type (DS). Material: stainless steel.
 - I **Strainer.** Stainless steel AISI 316. 156 holes 1/2" dia.
- Fasteners.** Stainless steel AISI 316.

Approval:

CSA approved to UL Standard #778.



Controls (not shown).

Manual controls, providing short circuit and overload protection, housed in NEMA 4X (watertight, corrosion resistant) plastic enclosures. Level control Model 8.408/4 (with float switches) or Flygt probe) available for automatic, unattended operation.

Accessories.

Tandem connection.

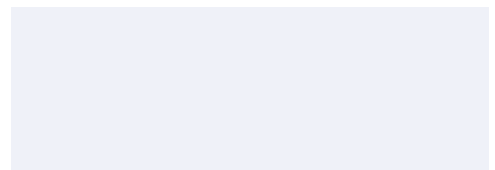

Flygt products are affiliated with the following associations:

