

# Installation and application

Leakage detectors, CLS/FLS/FLS10/FLS30/MiniCAS II

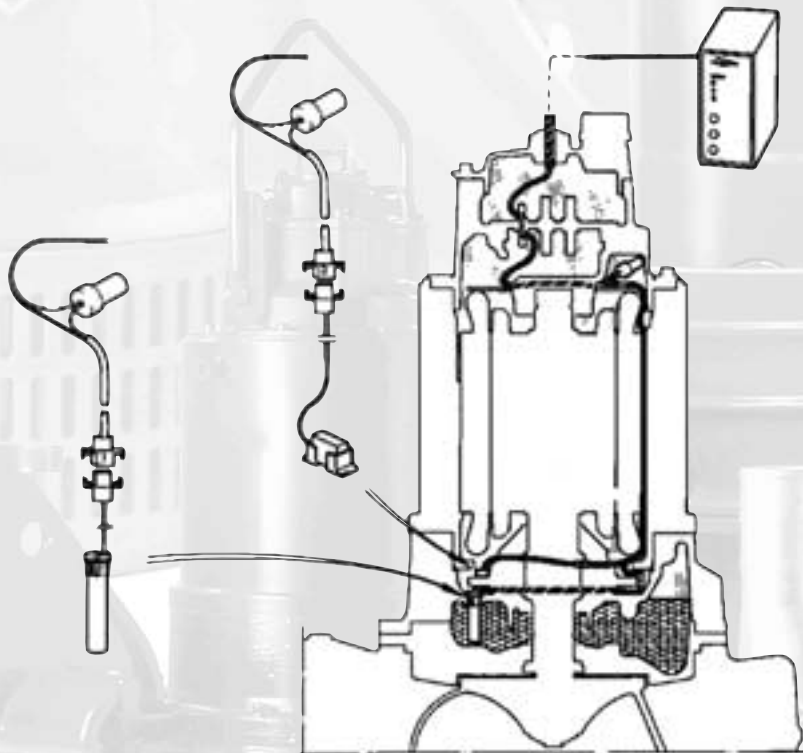

# INTRODUCTION

A number of condition monitoring sensors are available for the ITT FLYGT pump range.

- **Thermal switches** for stator overtemperature.
- **CLS** for water in oil detection.
- **FLS** for the detection of liquid in the stator housing.
- **FLS10** for detection of liquid in the inspection chamber in the new midrange pump series, eg 3153, 3171 and 3202.

- **FLS30** for detection of liquid in the inspection chamber or the stator housing in the new mixers, eg 4610 and 4620.

Any combination of these sensors can be used with the standard versions of the pumps. **Explosion proof** approved pumps are restricted to the use of the thermal switches with or without **FLS** and **FLS10** only.

The sensors are monitored by the ITT FLYGT **MiniCAS II** supervision relay, which is situated in the panel.

## BASIC SENSOR CONNECTIONS (6 alternative sensor combinations)

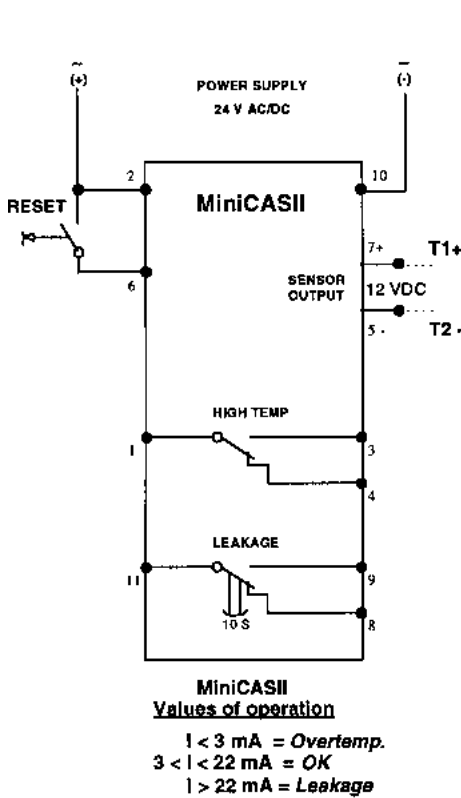

Circuits shown de-energised

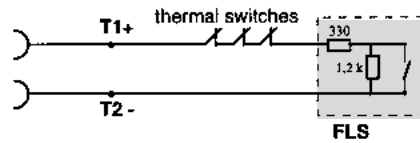

- FLS + thermal sw.** (1)  
 0 mA = *Overtemperature*  
 7,8 mA = *OK*  
 36 mA = *Leakage*  
 Tolerance 10%

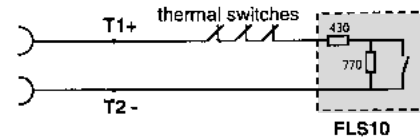

- FLS10 + thermal sw.** (2)  
 0 mA = *Overtemperature*  
 10 mA = *OK*  
 28 mA = *Leakage*  
 Tolerance 10%

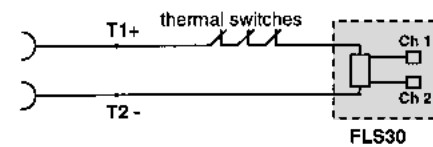

- FLS30 + thermal sw.** (3)  
 0 mA = *Overtemperature*  
 8 mA = *OK*  
 28 mA = *Leakage channel 1*  
 36 mA = *Leakage channel 2*  
 56 mA = *Leakage channel 1+2*  
 Tolerance 10%

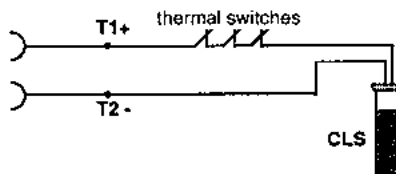

- CLS + thermal sw.** (4)  
 0 mA = *Overtemperature*  
 5,5 mA = *OK*  
 29 mA = *Leakage (5s delay)*  
 Tolerance 10%

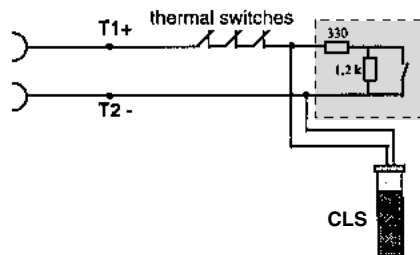

- Therm. sw. + FLS + CLS** (5)  
 0 mA = *Overtemp.*  
 13,3 mA = *OK*  
 36-42 mA = *Leakage (0/5s delay)*  
 Tolerance 10%

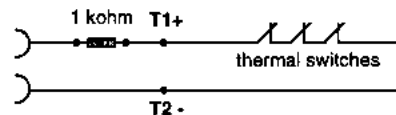

- Thermal sw. + 1kohm resistor** (6)  
 0 mA = *Overtemperature*  
 12 mA = *OK*  
 Tolerance 10%

## NOTES

1. Amber LED indicates supply on.
  - Overtemperature relay energised when healthy.
  - Leakage relay de-energised when healthy.
  - Red overtemperature LED off when healthy.
  - Red leakage LED off when healthy.
2. MiniCAS II resets automatically after leakage fault. MiniCAS II requires resetting after overtemperature fault. Please see "Technical Data".
3. There is not a separate indication when two leakage sensors are used.

# INSTALLATION

## The monitoring connections at the panel

The **MiniCAS II** supervision relay is installed in the pump panel and simply plugs into an eleven pin relay base. Six basic sensor connections are possible.

### 1. Thermal switches with FLS

The pilot cores in the pump can be connected to the panel in either polarity.

### 2. Thermal switches with FLS10

The pilot cores in the pump can be connected to the panel in either polarity.

### 3. Thermal switches with FLS30

The **FLS30** sensor is diode protected. For this reason the pilot cores are required to be connected with the correct polarity (brown = +, blue = -). Connected incorrectly the **MiniCAS II** supervision relay will indicate an open circuit (0 mA), i.e. with the amber supply LED and the red overtemperature LED **both** on. Connected correctly and reset, the amber LED **only** will be on.

### 4. Thermal switches with CLS

The **CLS** sensor is diode protected. For this reason the pilot cores are required to be connected with the correct polarity (brown = +, black = -). Connected incorrectly the **MiniCAS II** supervision relay will indicate an open circuit (0 mA), i.e. with the amber supply LED and the red overtemperature LED **both** on. Connected correctly and reset, the amber LED **only** will be on.

### 5. Thermal switches with CLS + FLS

The pilot cores in the pump cable are required to be connected with the correct polarity (brown = +, black = -), however, because the **FLS** will cause the **MiniCAS II** to indicate healthy, i.e. amber LED **ON**, even when incorrectly connected **CLS**, a current reading of the monitoring circuit must be taken when installing the pump. Correct polarity will indicate 15.0 mA; incorrect polarity will indicate 7.8 mA with healthy conditions.

### 6. Thermal switches only

A 1000—1500 ohm resistor must be connected in series with the thermal overtemperature switches. A 1000 ohm resistor is enclosed in the package.

MiniCAS II supervision relay

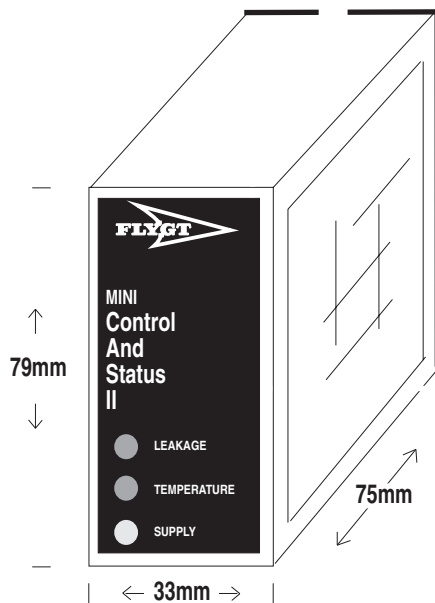

11 pin relay base

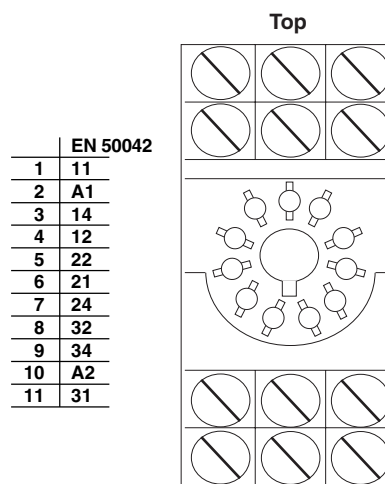

Part-no.: 84 55 67

## Variable frequency inverter controlled pumps/mixers

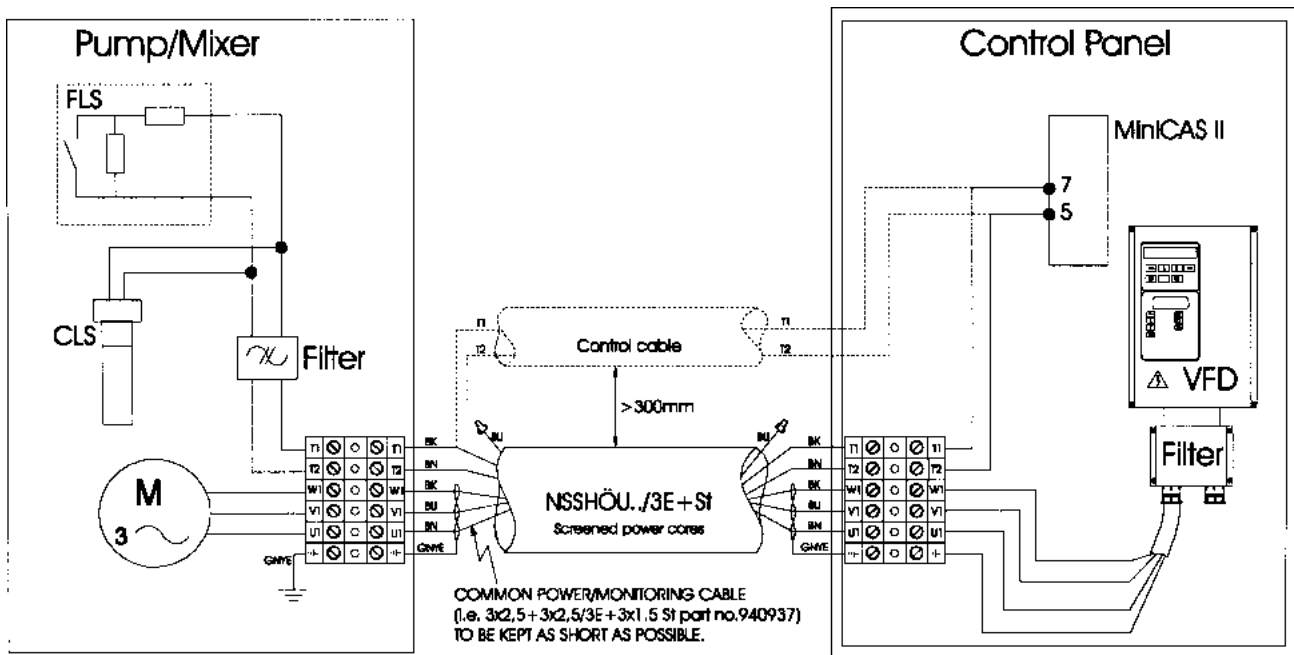

In installations utilising variable frequency inverters for speed control of pumps, interference from a variable frequency drive (VFD) may cause nuisance tripping of monitoring equipment and the electronic sensor CLS.

VFD-interference does not affect FLS and FLS10.

Interference occurs when the pilot cores are in close proximity to the power cores.

The interference may be suppressed by connecting a suitable filter<sup>1</sup> between the monitoring conductors (T1, T2) and ground (PE).

The filter should ideally be situated in the pump/mixer junction box.

Cables containing both power and pilot cores should be kept to a minimum length.

The power cable and control cable should be run in separate cable ducts with a distance of at least 300 mm between them.

Our pumps are CE-marked according to EMC-directive and the VFD that we buy from a subcontractor should also be CE-marked. In order to make the VFD pass the EMC-tests the interconnecting cable between pump and VFD has to be **screened**.

### <sup>1</sup>Available filter kits:

#### **Part no. 6046800**

Will fit: 3102, 3127, 4430.

#### **Part no. 6046801**

Will fit: 3085, 4410.

#### **Part no. 6046802**

Will fit: 3140, 3152, 3170, 3201, 3300.

#### **Part no. 6046804**

Will fit: 3231, 3306, 3312, 3351, 3356, 3400, 3501, 3602, 3800, 7045, 7061, 7081, 7101, 7115, 7121.

#### **Part no. 6616000**

Will fit: 4630, 4640, 4650, 4660.

#### **Part no. 6616001**

Will fit: 4670, 4680.

604 68 00

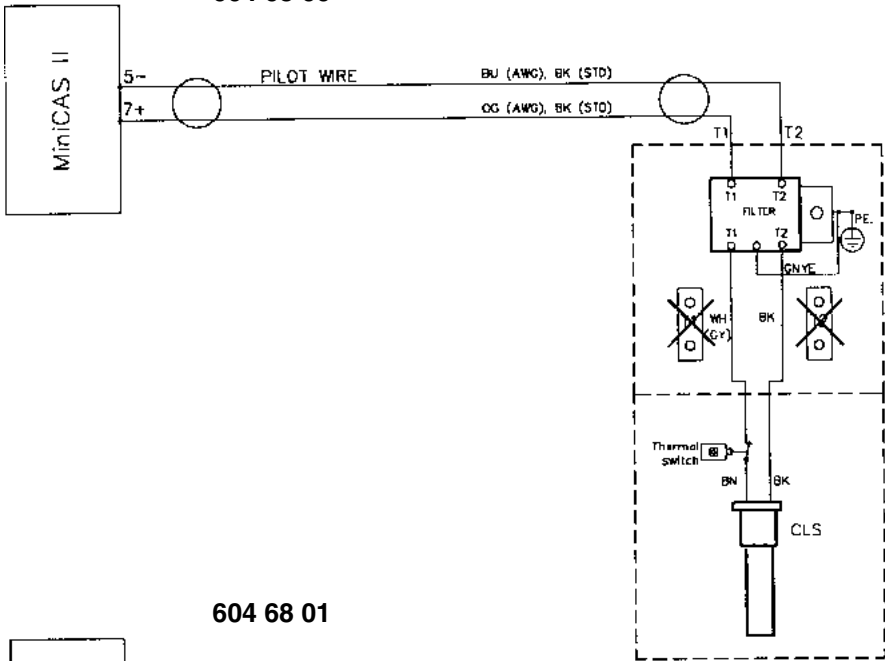

JUNCTION BOX

Remove connection from terminals T1,T2, when using filter

604 68 01

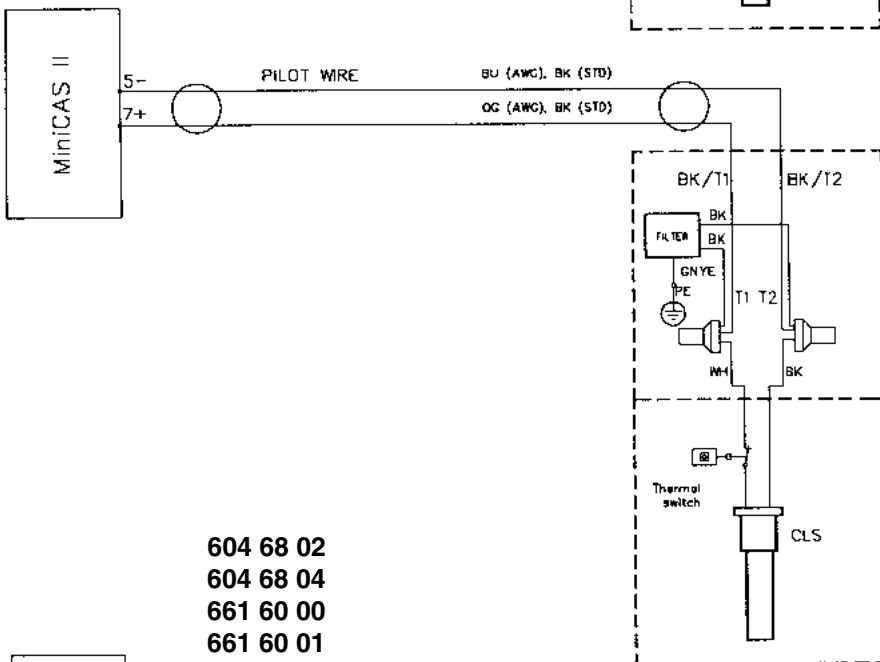

JUNCTION BOX

604 68 02  
604 68 04  
661 60 00  
661 60 01

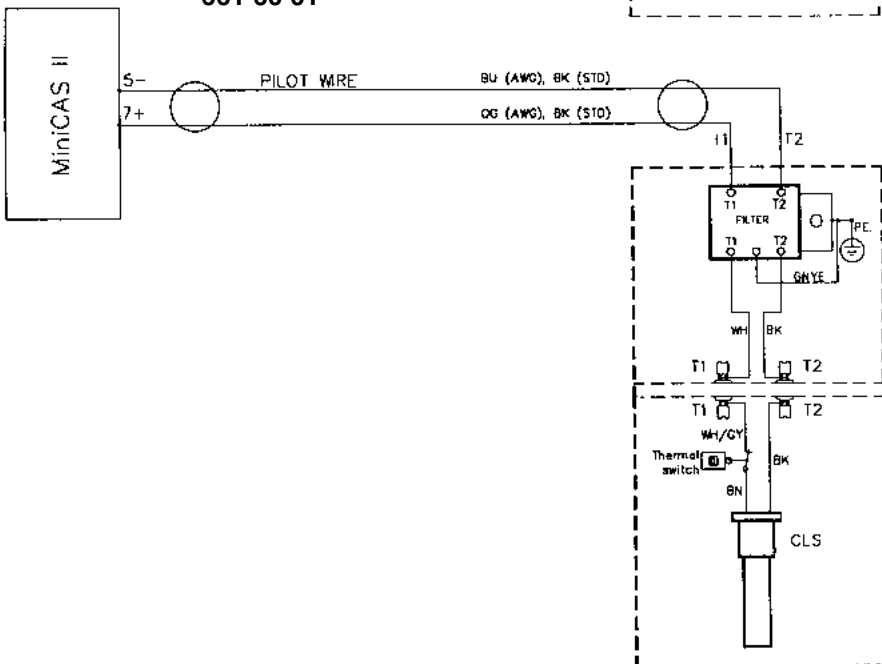

JUNCTION BOX

## Checking the sensor circuit and fault finding

Connect a multimeter in series with the sensors or use the ITT Flygt sortester "ST-1" (FD part no. 10-581700) to measure the current in the sensor circuit. See figures below.

"ST-1" is not yet prepared to handle the new sensors FLS10 and FLS30 (jan-2001).

The figures on page 2 is used as reference to determine the status of the sensors (sensor connections).

Circuits with CLS require some extra consideration. Connected with wrong polarity the CLS draws a zero current. The CLS can then be considered not connected.

Wrong polarity results in 0 mA for circuit (3) and circuit (4). Circuit (5) is reduced to the same as circuit (1).

As opposed to the FLS, FLS10 and FLS30, the CLS has a built-in alarm delay of 5 seconds.

Since the MiniCASII has only one leakage indication lamp, an alarm from the CLS or the FLS looks the same.

For circuit (5), this means that a leakage alarm can not be attributed to either of the two sensors just by looking at the MiniCASII. To make out the tripping sensor without lifting the pump, a measurement of the sensor current is necessary.

### Sensor current measurement using a multimeter

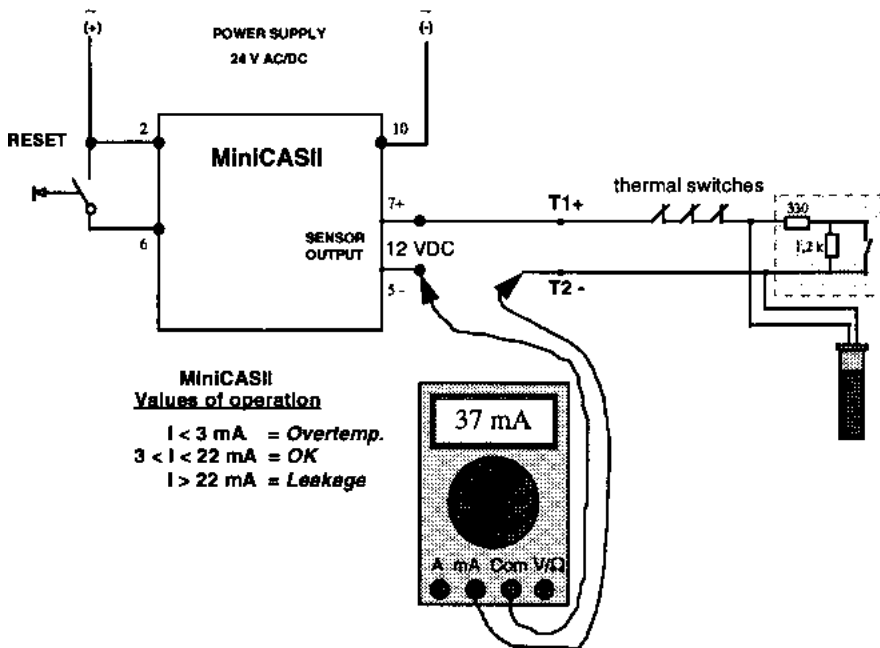

**MiniCASII**  
**Values of operation**  
 $I < 3 \text{ mA} = \text{Overtemp.}$   
 $3 < I < 22 \text{ mA} = \text{OK}$   
 $I > 22 \text{ mA} = \text{Leakage}$

**Therm sw. + FLS + CLS**  
 $0 \text{ mA} = \text{Overtemp.}$   
 $13,3 \text{ mA} = \text{OK}$   
 $36-42 \text{ mA} = \text{Leakage (0/5s delay)}$   
 Tolerance 10%

### General procedure to check the status of the sensors

1. Close the sensor circuit by connecting the multimeter test leads according to figure above or on next page.
2. From the moment contact is made, observe the sensor current for at least 5 seconds (to await a possible CLS alarm current).
3. Switch polarity of the sensor leads (5, 7) and repeat steps 1 and 2.
4. Identify the actual sensor circuit with the help of the first page figure and analyse the sensors' status.
5. In case circuit (5) is used: By using the wrong polarity and delay properties of the CLS, it is possible to conclude if a leakage alarm is attributed to the CLS or FLS.
6. To ensure that the polarity is right after the measurement, restore the connection resulting in the largest current.

### To be noted

A zero current may be the result of a broken sensor lead or an open thermal switch.

A leakage alarm may be caused by a short circuit due to pinched sensor leads or a correct leakage signal from FLS, FLS10, FLS30 or CLS.

## Sensor current measurement using ST-1

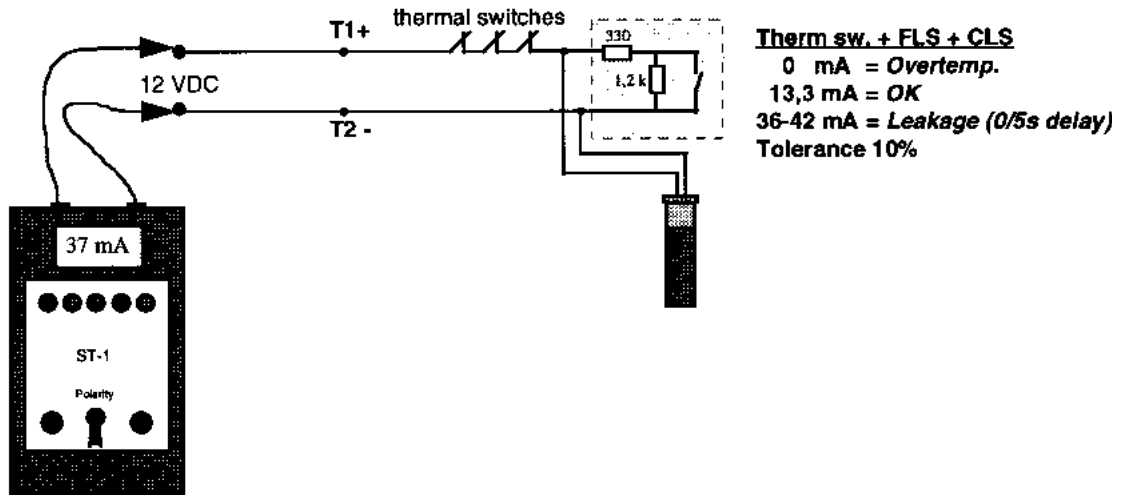

### Checking earth faults

Earth faults on the monitoring cores must be checked for and avoided as they may cause spurious seal leakage indications. Fault finding of this nature should only be carried out using a multimeter ohms scale and not an insulation tester utilising 500 V or above as a test voltage.

Measure between each sensor lead and earth. Ideally the value should be infinite but Mega ohm values are acceptable.

## Earth fault measurement

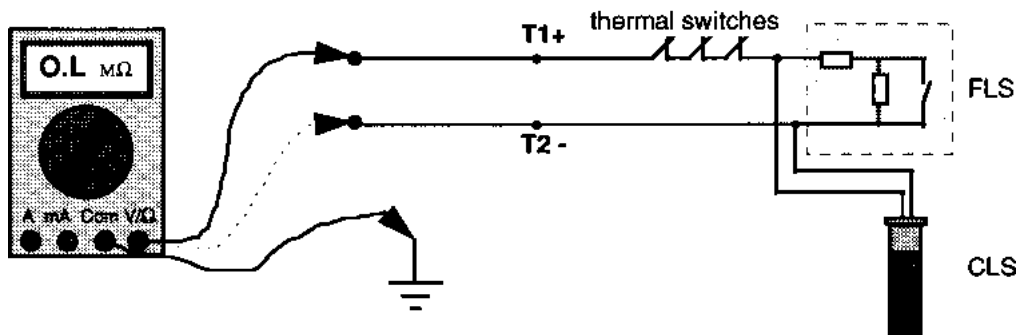

## Checking the MiniCASII

The MiniCASII can be checked by using loose sensors connected to the sensor output or by simulating the sensors using resistors.

A simple test can be performed with a resistor, for example the one enclosed in the delivery package (1 kohm):

Connect the MiniCASII supply input, 2 and 10, to the correct voltage: 24 V AC/DC.

### Simulating normal condition

Connect a resistor of between 1 kohm to 1,5 kohm to the 12 VDC sensor outputs 5 and 7. If a multimeter is available it can be connected in series with the resistor (see fig.) Reset the MiniCASII by shortly connecting and disconnecting a lead between outputs 2 and 6. Now, the SUPPLY lamp only should be lit.

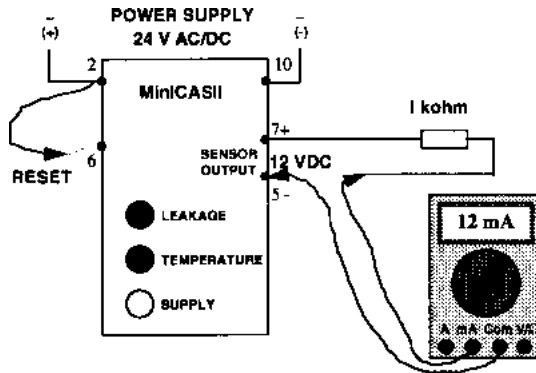

### MiniCASII Values of operation

- $I < 3 \text{ mA} = \text{Overtemp.}$
- $3 < I < 22 \text{ mA} = \text{OK}$
- $I > 22 \text{ mA} = \text{Leakage}$

The mA reading with a 1 kohm resistor:  $12 \text{ V} / 1000 \text{ ohm} = 12 \text{ mA}$ .

### Simulating temperature alarm

If nothing is connected to the sensor outputs 5 and 7 (open circuit), the SUPPLY and TEMPERATURE lamps are both lit. The current is obviously zero mA.

### Simulating leakage alarm

The leakage condition can be checked by connecting a 500 ohm (or less) resistor to the sensor outputs 5 and 7. It is fine to short circuit the output with the multimeter or a jumper. Note that there is a 10 s delay<sup>1</sup> before the LEAKAGE lamp is lit. The TEMPERATURE lamp may or may not be lit depending on if the MiniCASII has been reset.

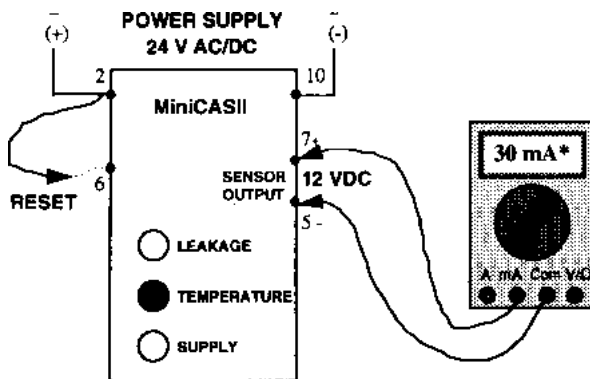

### MiniCASII Values of operation

- $I < 3 \text{ mA} = \text{Overtemp.}$
- $3 < I < 22 \text{ mA} = \text{OK}$
- $I > 22 \text{ mA} = \text{Leakage}$

\* At short circuit, MiniCASII limits the current to 30 mA

<sup>1</sup> The MiniCASII has been updated at one occasion. Both versions have part no 835857 but are easily distinguished by looking at the circuit diagram on the side of the unit. Check the delay of the leakage alarm.

The original version has a 5 s delay.

The updated version has a 10 s delay. This version also has an improved noise protection. In some cases where noise, generated by a *variable frequency drive*, has made the original version fail, the new version works.



# TECHNICAL DATA

## MiniCAS II supervision relay

Operational principle:	Current Sensing
Approvals:	CE, C-UR (covering USA and Canada)
Environment:	-25 to 60°C (maximum 90% relative humidity)
Supply voltage:	20-30 VAC (50-60Hz) 23.5-30VDC
Relay contact rating:	250 VAC / 8A
Voltage to sensor:	12 VDC +/-5%
Values of operation:	3mA < I < 22mA = OK condition I < 3mA = High temperature (or interruption) I > 22mA = Leakage (or short circuit), 10 s delay of alarm ( I = current measured by MiniCAS II )
Power supply required:	5 VA

## OPERATION

Leakage:	Changeover contacts	11-8 Normally closed for interlock 11-9 Closes for alarm
	Automatic reset	
	Red LED for indication – follows the relay	
	Red indication lamp on:	Leakage
	Red indication lamp off:	No leakage
Temperature:	Changeover contacts	1-3 Closes for interlock when energised 1-4 Normally closed for alarm
	Manual reset (see below)	
	Red indication lamp on:	Overtemperature
	Red indication lamp off:	Normal temperature
<i>Reset of Temperature Alarm:</i>	External reset is possible either by connecting terminals 6-2 with an external push button or by interrupting the 24V supply	

**DIMENSIONS:** Width 33 mm  
Height 79 mm  
Depth 75 mm

**PART NO:** 83 58 57

# TECHNICAL DATA

## CONNECTIONS

### Leakage alarm will stop the pump

This installation can be used if the leakage alarm shall stop the pump.

It is recommended if the FLS sensor is used. The FLS is detecting liquid in the stator housing, which is critical and requires a quick stop of the pump.

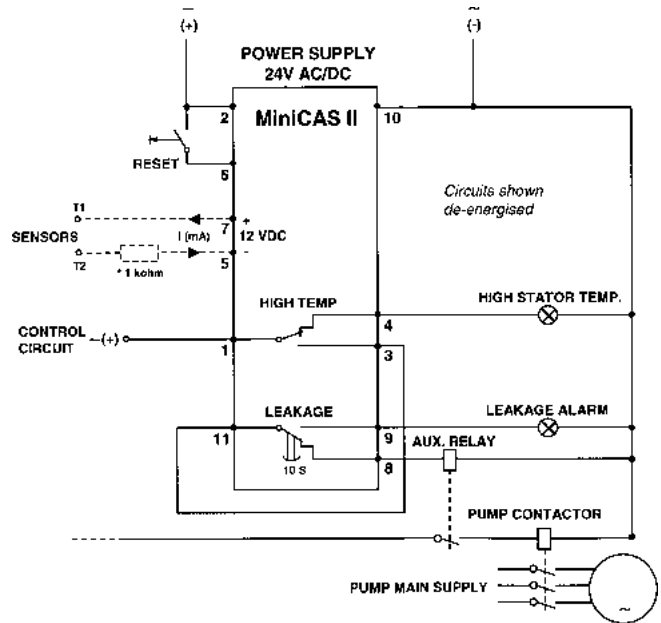

**WARNING:**  
Switch off power supply before working with the MiniCAS II socket. There may be a high voltage at the socket connections.

### Leakage alarm will not stop the pump (only warning)

This installation can be used if the leakage alarm shall not stop the pump but give a warning on the MiniCASII.

It is recommended if FLS10, FLS30 in inspection chamber or CLS is used. These sensors detect liquid in the inspection chamber (FLS10 and FLS30) and water in the oil (CLS), which is less critical than water in the stator housing.

FLS10 is used in the new midrange pump series, eg 3153, 3171 and 3202.

FLS30 is used in the new mixers, eg 4610 and 4620.

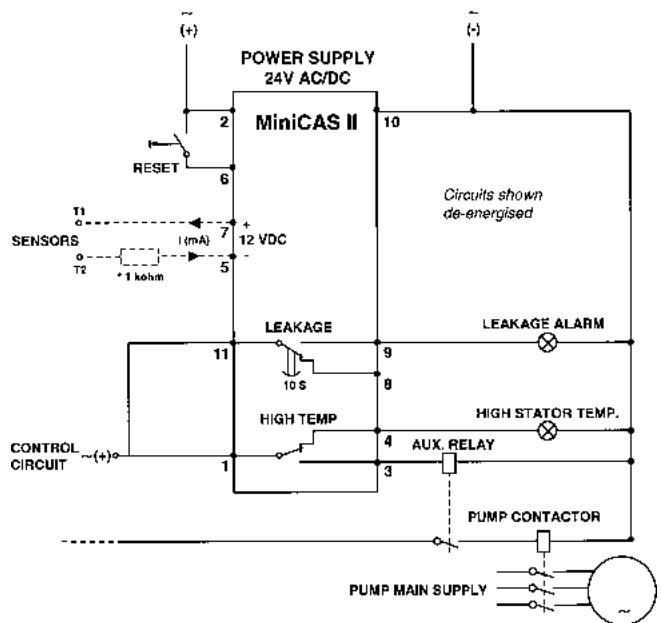

\*) Fit resistor to avoid short circuit if only thermal contacts are to be connected.

# TECHNICAL DATA

## FLS stator leakage sensor

Signal:	8 mA non-alarm current, 36 mA alarm current
Supply voltage:	12 VDC
Max. temperature:	90°C, 1h
Test temperature:	115°C, 1h
Max. duty temperature:	70°C
Material:	Aluminium

### Physical size, sensor

Length:	27 mm
Width:	16 mm
Height:	16 mm

**Part Number** 518 89 02

## CLS water in oil sensor

Trip emulsion:	35% of water in oil
Signal:	5.5 mA non-alarm current, 29mA alarm current (5 s delay of alarm)
Poles:	2 wires protected with a diode (wrong polarity connection = 0 mA)
Supply voltage:	12 VDC (± 10 %) (brown = +, black = -)
Metal parts:	Acid proof stainless steel
Sensor surface:	Glass
Max. pressure:	10 MPa 1h
Test pressure:	40 MPa
Duty pressure:	2 MPa
Max. temperature:	90°C, 1h
Test temperature:	115°C, 1h
Max. duty temperature	70°C

### Physical size, sensor

Length:	75 mm
Diameter:	12 mm
Thread:	M16 × 1.5, length 15 mm

**Part number:** 505 12 00

## FLS10 inspection chamber sensor

Signal:	10 mA non-alarm current, 28 mA alarm current
Supply voltage:	12VDC
Max. duty temperature:	90°C
Material:	Stainless steel and nitril rubber

### Physical size, sensor

Length:	44 mm
Diameter:	22 mm
Thread:	M12 × 1, length 9 mm

**Part number** 608 26 00

## FLS30 leakage sensor

Signal:	8 mA non-alarm current 28 mA alarm current channel 1 36 mA alarm current channel 2 56 mA alarm current channel 1+2
Supply voltage:	12VDC (brown = +, blue = -)
Max. duty temperature:	Sensor 80°C, Processor 70°C
Material:	Aluminium and PVDF

### Physical size, sensor

Length:	19 mm
Diameter:	12 mm

### Physical size, processor

Length:	37 mm
Width:	22 mm
Height:	18 mm

**Part number, sensor** 659 39 00

**Part number, processor** 659 86 00

**Warning: Sensor body made of glass.  
Handle with care.**



[www.flygt.com](http://www.flygt.com)